

NOTE: DO NOT DISCARD the Parts List from the Instruction Bulletin. Place the Parts List in the appropriate place in the machine manual for future reference. Retaining the Parts List will make it easier to reorder individual parts and will save the cost of ordering an entire kit.

NOTE: Numbers in parenthesis () are reference numbers for parts listed in Bill of Materials.

Installation instructions for **kit number 9001327**

SYNOPSIS:

This kit contains the parts needed to install a flashing light kit on M20 and T20 machines. Please follow step-by-step instructions.

SPECIAL TOOLS / CONSIDERATIONS: NONE

(Estimated time to complete: 1 hour)

PREPARATION:

1. Park the machine on a clean level surface, turn off the machine, remove the key, and set the parking brake.

FOR SAFETY: Before leaving or servicing machine, stop on level surface, set parking brake, turn off machine, and remove key.

2. Disconnect the negative terminal and then the positive terminal from the battery.



WARNING: Always disconnect battery cables from machine before working on electrical components.

INSTALLATION:

1. Route the wires from the lamp (1) down through the hole in the light support bracket (5) and use a hex screw (2), flat washer (3), and hex nut (4) to install the lamp onto the light support bracket. Refer to Fig. 1.

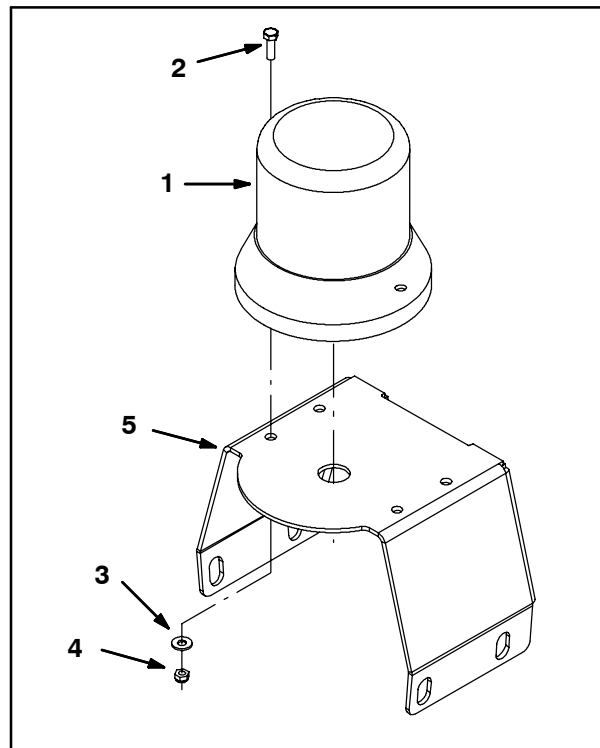

FIG. 1

- Route the wires from the lamp (1) through one cable clamp (9) and use a hex screw (2), two flat washers (3), and hex nut (4) to install the cable clamp underneath the lamp support bracket (5) and completely secure the lamp to the light support bracket. Refer to Fig. 2.

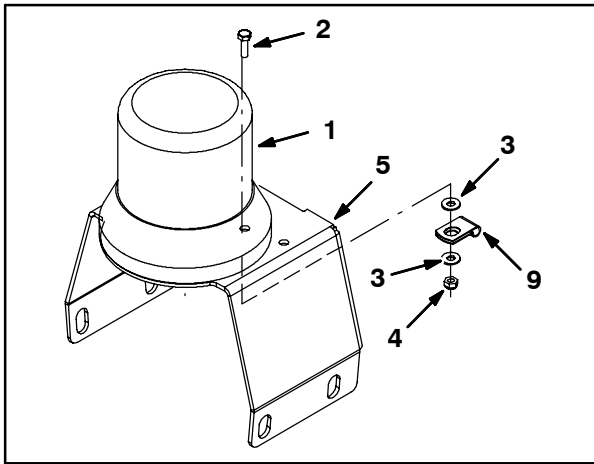

FIG. 2

- Open the recovery tank cover and pull the main wire harness backup alarm and revolving light connector from between the recovery and solution tank. Connect the warning/backup harness (8) to the main wire harness. Refer to Fig. 3 or Fig. 4, and Fig. 9.

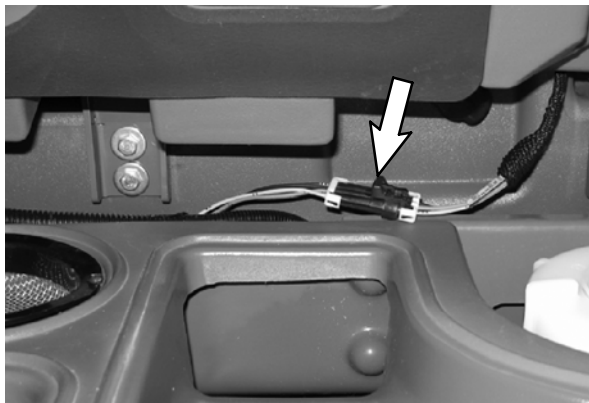

FIG. 3 - M20 Harness Location

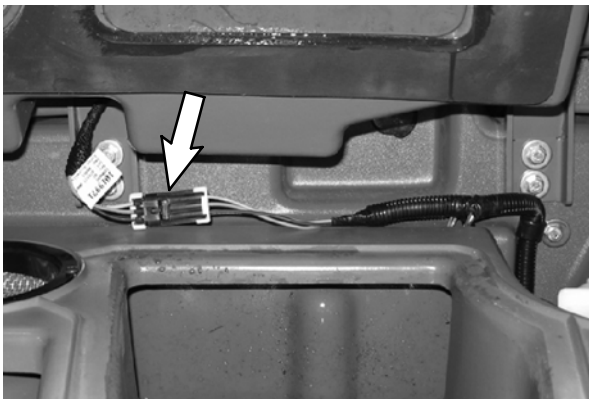

FIG. 4 - T20 Harness Location

- Route the warning/backup harness (8) through the notch in the solution tank and install a cable clamp (9) onto the warning/backup harness. Refer to Fig. 6.
- Use three hex screws (6) and three flat washers (7) to install the light support bracket (5) onto the solution tank. Refer to Fig. 5.

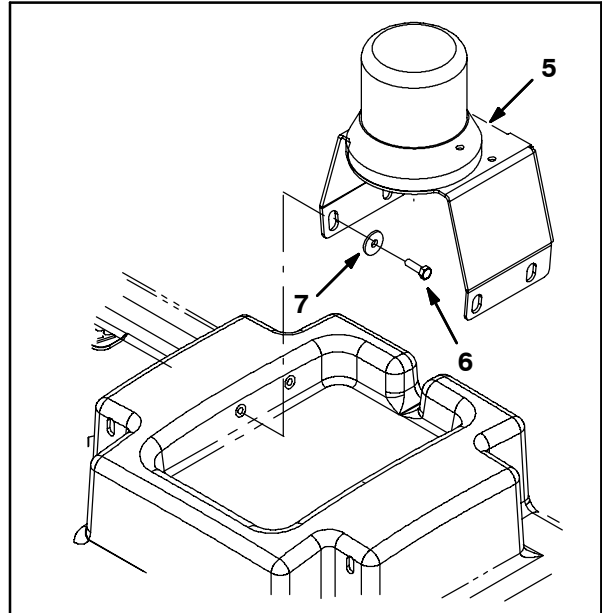

FIG. 5

- Use a hex screw (6) and flat washer (7) to install the cable clamp (9) on the warning/backup harness (8) onto light support bracket (5) and solution tank. Refer to Fig. 6.

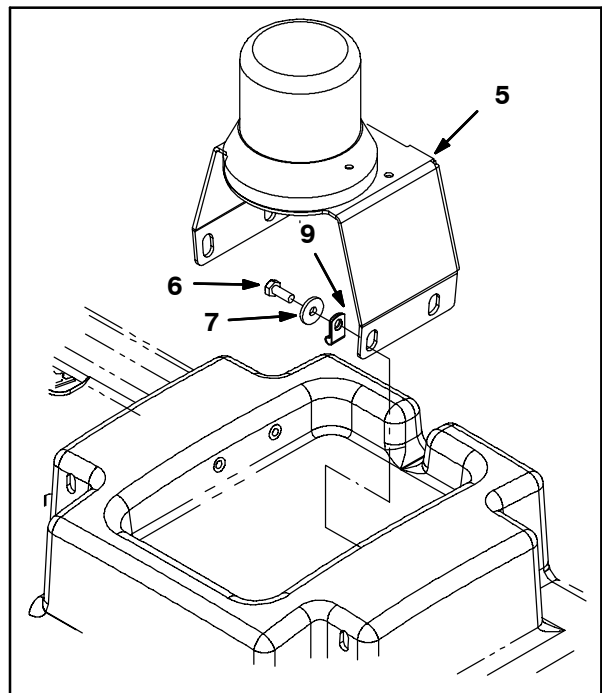

FIG. 6

7. Connect the warning/backup harness (8) to the light (1). Refer to Fig. 8 and Fig. 9.
8. Neatly bundle remaining length of the warning/backup harness (8) and use a cable tie or electrical tape to hold the bundled wire together. Refer to Fig. 7.

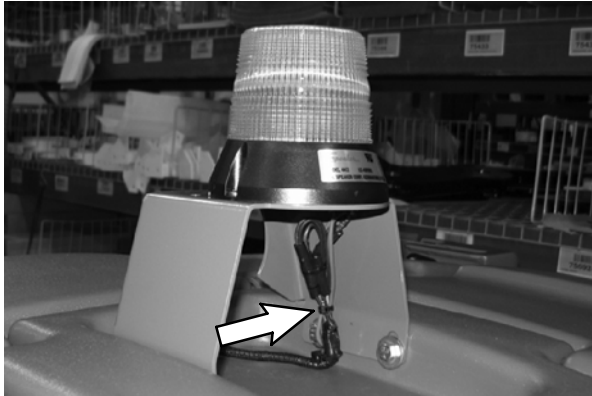

FIG. 7

9. Slide the main wire harness backup alarm and revolving light connector and attached connector from the warning/backup harness (8) back down between the recovery and solution tank and close the recovery tank cover. Refer to Fig. 3 or Fig. 4.
10. Reconnect the positive terminal and then the negative terminal to the battery.
11. Start the machine and test the light.

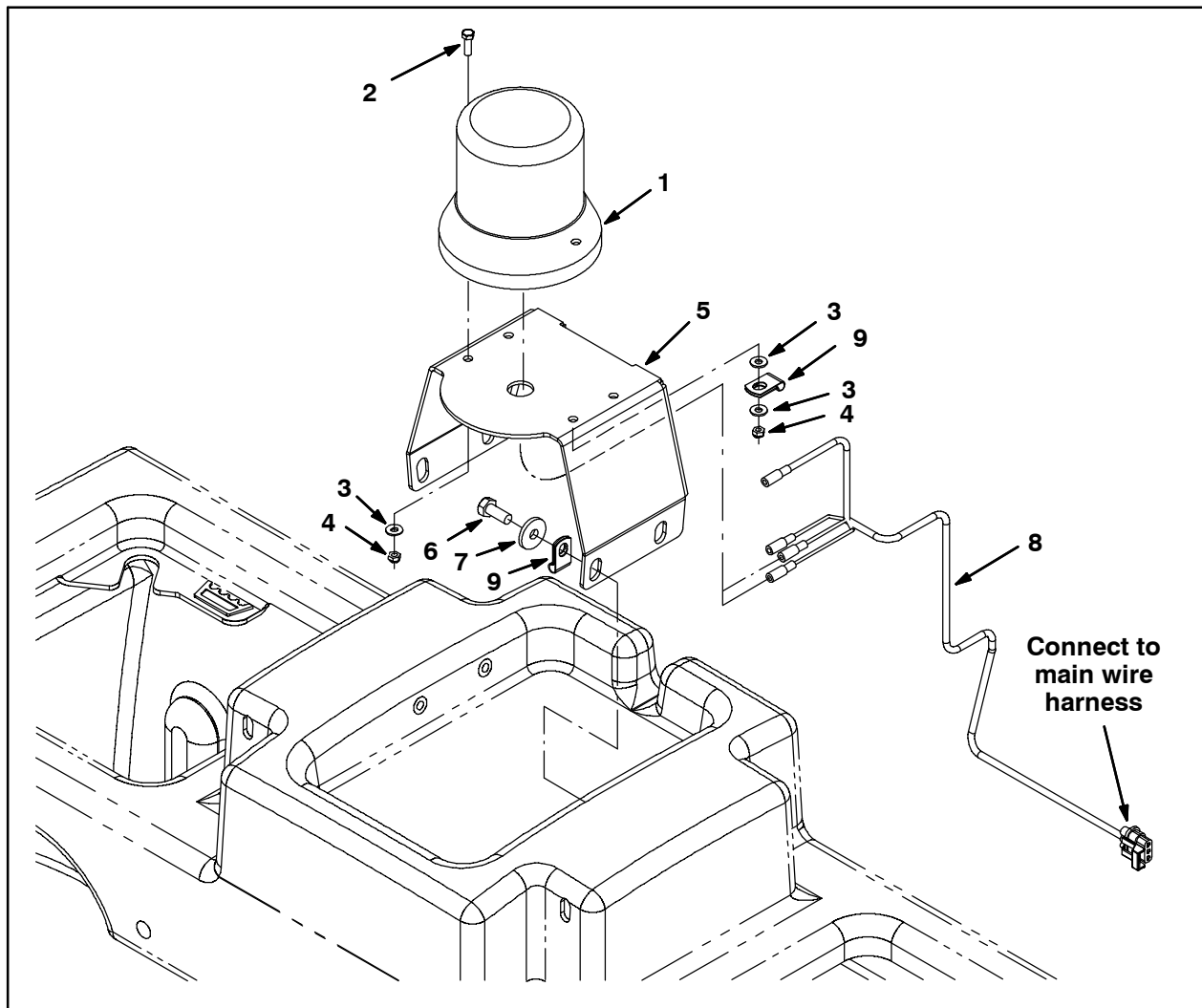

FIG. 8

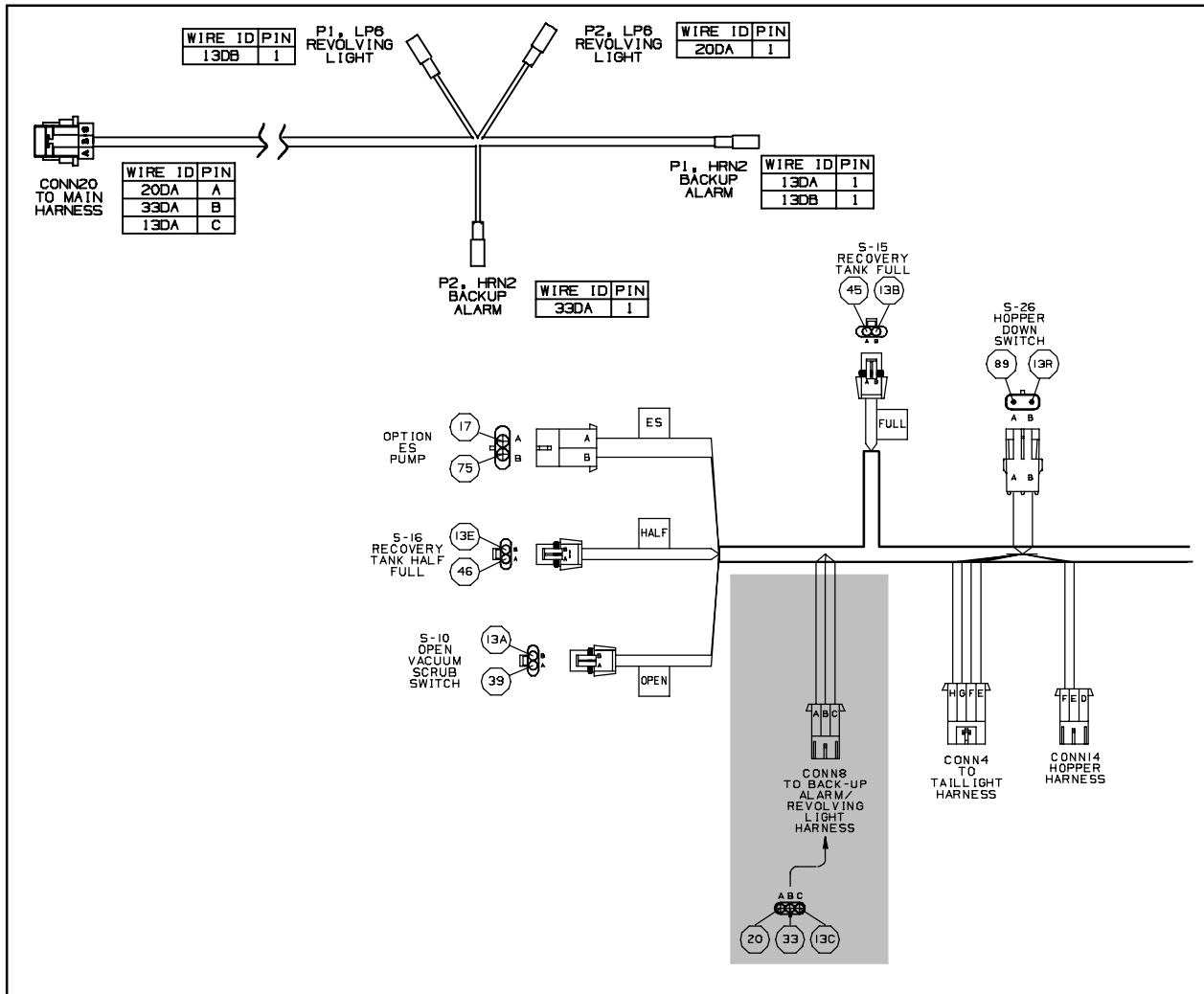

FIG. 9

Bill of Materials for Light Kit, Flsh, CI [M20 And T20]-9001327

| Ref. | Tennant Part No. | Description | Qty. |
|------|------------------|---|------|
| ▽ | 9001327 | Light Kit, Flsh, Ci [M20 And T20] | 1 |
| ▲▽ | 1 1017248 | Lamp, Flasher, Amb [12-48 Vdc] | 1 |
| ▲▲ | 9000879 | Lens, Lamp, Amb, Strobe/Flasher | 1 |
| ▲▲ | 9000845 | Lamp, Bulb, Lamp, Flsh | 1 |
| ▲▲ | 55272 | Terminal, Bullet, Mal, .157d, 12ga | 2 |
| ▲ | 2 24196 | Screw, Pan, M5 X 0.8 X 20, SS | 2 |
| ▲ | 3 19066 | Washer, Flat, #10 | 2 |
| ▲ | 4 09739 | Nut, Hex, Lock, M5 X 0.8, NI, SS | 2 |
| ▲ | 5 1019445 | Bracket, Sppt, Revl Light | 1 |
| ▲ | 6 09740 | Screw, Hex, M8 X 1.25 X 20, SS | 4 |
| ▲ | 7 1017218 | Washer, Flat, 0.32b 1.00d .12, SS | 4 |
| ▲ | 8 1019971 | Harness, Warning / Backup [M20 & T20] | 1 |
| ▲ | 9 46236 | Clamp, Cable, Stl, 0.25D X 0.56W, 1Hole | 2 |

TENNANT COMPANY
P. O. Box 1452
Minneapolis, MN 55440-1452